



Royale Air Carbon Fibre Folding Scooter
User Manual

Contents

SECTION	TITLE	PAGE
1	Introduction	2
2	Safety & Precautions	4
3	Features	15
4	Specifications	16
5	Instructions of Use	19
6	Transporting the Scooter	26
7	Labelling Information	28
8	Product Care & Maintenance	29
9	Recycling & Disposal	32
10	Trouble Shooting	33
11	Warranty	36
12	Battery Material Safety Data Sheet (MSDS)	38

No part of this user manual may be copied, distributed, reproduced, duplicated, scanned or stored whether in whole or part in any form or by any means without the expressed written consent from the officers of Independent Living Specialists Pty Ltd. Independent Living Specialists does not accept responsibility for any changes, errors or omissions. All information is subject to change without prior notice and products may vary from that of the actual images depicted.

1 Introduction



S344969 - Scooter - Royale Air Carbon Fibre Folding + Suited Lithium Batteries (includes 2x 6AH Batteries)

Thank you for purchasing your Royale Air Carbon Fibre Folding Scooter.

As part of ongoing product development, product specifications may change without prior notice.

Any updates that affect safety or usage for existing users will be clearly communicated.

Please note: All dimensions are approximate and may vary.

This product is designed for an intended service life of 5 years. To ensure safe and optimal performance, only use components or accessories that are officially approved for this model.

This user manual will help you to use and maintain your scooter safely.

Do not use your scooter until this manual and all relevant booklets have been read and understood. If the user manual was not included with your scooter, please contact your dealer immediately.

2 Safety & Precautions

2.1 Temperature

Avoid touching the scooter motors at any time. During operation, the motors remain in motion and can become very hot. After use, allow at least 30 minutes for them to cool down before making contact, as touching them too soon may cause burns.

When the scooter is not in use, keep it out of direct sunlight for prolonged periods. Parts such as the seat, backrest, armrests and handlebars can heat up significantly when exposed to the sun, potentially causing burns or skin irritation.

The recommended storage conditions for the scooter are as follows:

- Temperature range: -20°C to 50°C
- Relative humidity: not exceeding 90%
- Atmospheric pressure: 56 - 100 kPa

The scooter should be stored in a well-ventilated area, free from harmful or corrosive gases. Do not stack or place heavy objects on top of the scooter.

Avoid storing the product near heat sources or in direct sunlight for extended periods.

If the scooter will not be used for a long time, ensure it is fully charged and powered off before storage. For storage periods exceeding one month, recharge the battery fully before resuming use or continuing storage.

2.2 Moving Components

A scooter contains several moving components. Contact with these parts can cause serious injury or damage to the scooter or user and should always be treated with caution.

Wheels (front and rear)
Rotating armrests
Height adjustable tiller
Scooter folding mechanism

2.3 Electromagnetic Radiation

The scooter has been tested to meet applicable electromagnetic compatibility (EMC) requirements. However, despite these tests, electromagnetic interference cannot be completely ruled out.

External sources of electromagnetic radiation - such as mobile phones, large medical equipment, or other strong emitters - may affect the scooters performance.

Similarly, the scooter itself may cause interference with certain electromagnetic systems, including:

- Automatic shop door
- Security or anti-theft systems in stores
- Remote-controlled garages

If you experience any such interference or operational issues, please contact your dealer immediately.

When using two-way radios, walkie-talkies, CB radios, amateur radios, public mobile radios, or any other high-powered transmitting devices, the scooter must be brought to a complete stop and switched off. Use of cordless phones, mobile phones, and hands-free devices is allowed; however, if any irregular or abnormal operation of the scooter occurs, stop immediately and turn the scooter off.

2.4 Electromagnetic Interface (EMI)

Electromagnetic interference (EMI) is caused by external electromagnetic energy sources such as radios, television transmitters, CB radios, garage door openers, and cordless or mobile phones. Such interference may affect the scooter control system.

In certain cases, EMI can result in unintended behaviour — including brake failure, unexpected power activation, steering malfunction, or even permanent damage to the control system.

The following cable information is provided for reference to ensure compliance with electromagnetic compatibility (EMC) requirements.

Cable	Max. cable length		Number	Cable Classification
	Shielded/unshielded			
AC Power Line	1.8m	Shielded	1 Set	AC Power
DC Power Line	1.2m	Shielded	1 Set	DC Power

Important Information on Electromagnetic Compatibility (EMC)

- This electrical medical device requires special precautions regarding EMC and must be operated in accordance with the EMC guidance provided in this user manual. The equipment complies with the IEC 60601-1-2:2014 standard for both immunity and emissions. However, certain precautions must still be observed.
- This equipment with essential performance, has been designed for indoor and outdoor use, includes essential performance features critical to its safe operation.
- **Warning:** Avoid using this equipment in close proximity to other electronic devices, as this may lead to improper operation. If simultaneous use is unavoidable, both devices should be monitored to ensure they function correctly.
- The use of accessories, transducers, or cables other than those specified or supplied by the manufacturer may increase electromagnetic emissions or reduce the device’s immunity, potentially leading to malfunction.
- **Warning:** Portable RF communication equipment (including antennas, cables, and external antennas) must be kept at least 30 cm (12 inches) away from any part of the scooter including its cables. Failure to do so may degrade performance.
- **Warning:** When operating the scooter strong AM, FM, or TV broadcast antennas (within approximately 1.5 km), verify that the equipment functions normally before use to ensure continued safety and correct performance throughout its service life.
- If the AC input power is interrupted during battery charging, the process will stop. Charging will automatically resume once the power supply is restored.

Guidance and manufacturer’s Declaration-electromagnetic emission

Air Carbon is intended for use in the electromagnetic environment specified below. The customer or the user of the Air Carbon should assure that it is used in such environment.

Emission Test	Compliance	Electromagnetic environment-guidance
RF Emission CISPR 11	Group 1	Air carbon scooter uses RF energy only for its internal function. Therefore, RF emissions are very low and are not likely to cause any interference in nearby electronic equipment.
RF Emission CISPR 11	Class B	Air carbon scooter is suitable for use in all establishments, including domestic establishment and those directly connected to the public low-voltage power supply network that supplies buildings used for domestic purposes.
Harmonic Emissions IEC 61000S-3-2	Class A	
Voltage fluctuation/flicker emissions IEC 61000S-3-3	complies	

Guidance and manufacturer's Declaration-electromagnetic emission			
Immunity test	IEC 60601 test level	Compliance level	electromagnetic environment-guidance
Electrostatic discharge (ESD) IEC 61000S-4-2	±6 kV contact ±8 kV air	±6 kV contact ±8 kV air	Floors should be wood, concrete or ceramic tile. If floors are covered with synthetic material, the relative humidity should be at least 30%.
Electrical fast transient/ burst IEC 61000S-4-4	±2kV for power supply lines ±1kV for input/ output lines	±2kV for power supply lines ±1kV for input/ output lines	Mains power quality should be that of a typical commercial or hospital environment.
Surge IEC 61000S-4-5	±1 kV differential mode ±2 kV common mode	±1 kV differential mode ±2 kV common mode	Mains power quality should be that of a typical commercial or hospital environment.
Voltage dips, short interruptions and voltage variations on power supply input lines. IEC 61000S-4-11	<5 % UT, (>95% dip in, UT) for 0.5 cycle 40 % UT (60% dip in, UT) for 5 cycles 70 % UT, (30% dip in, UT) for 25 cycles <5 % UT, (>95% dip in, UT) for 5 sec		Mains power quality should be that of a typical commercial or hospital environment. If the use of the Air Carbon Scooter requires continued operation during power mains interruptions, it is recommended that the Air Carbon Scooter be powered from an uninterruptible power supply or a battery. Power frequency magnetic fields should be at levels characteristic of a typical location in a typical commercial or hospital environment.
Power frequency (50/60Hz) magnetic field IEC 61000S-4-8	3A/m		

NOTE: UT is the ac mains voltage prior to application of the test level.

Guidance and manufacturer's Declaration-electromagnetic immunity			
Immunity test	IEC 60601 test level	Compliance level	electromagnetic environment-guidance
Conducted RF IEC 61000S-4-6	3 Vrms 150 kHz to 80 MHz	3 Vrms	Portable and mobile RF communications equipment should be used or closer to any part of the Air Carbon Scooter, including cables, than the recommended separation distance calculated from the equation applicable to the frequency of the transmitter. Recommended separation distance $d = 1.2 \sqrt{P}$ $d = 1.2 \sqrt{P}$ 80 MHz to 800 MHz $d = 2.3 \sqrt{P}$ 800 MHz to 2.5 GHz Where P is the maximum output power rating of the transmitter in watts(W) according to the transmitter manufacturer and d is the recommended separation distance in the meters(m). Field strengths from fixed RF transmitters, as determined by an electromagnetic site survey, should be less than the compliance level in each frequency range. Interference may occur in the vicinity of the equipment marked with the following symbol: 
Radiated RF IEC 61000S-4-3	3 V/m 80 MHz to 2.5 GHz	3 V/m	

NOTE 1: At 80MHz and 800MHz, the higher frequency range applies.
 NOTE 2: This guidance may not apply in all situations. Electromagnetic propagation is affected by absorption and reflection from structures, objects and people.

Field strengths from fixed transmitters, such as base stations for radio (cellular/cordless) telephones and land mobile radios, amateur radio, AM and FM radio broadcast and TV broadcast cannot be predicted theoretically with accuracy. To assess the electromagnetic environment due to fixed RF transmitters, an electromagnetic site survey should be considered. If the measured field strength in the location in which the Air Carbon Scooter is used exceeds the applicable RF compliance level above, the Air Carbon Scooter should be observed to verify normal operation. If abnormal performance is observed, additional measures may be necessary, such as reorienting or relocating the Air Carbon Scooter.
 Over the frequency range 150 kHz to 80 MHz, field strengths should be less than 3 V/m.

Recommended separation distances between portable and mobile RF communications equipment and the Air Carbon Scooter.

The Air Carbon Scooter is intended for use in an electromagnetic environment in which radiated RF disturbances are controlled. The customer or the user of the Air Carbon Scooter can help prevent electromagnetic interference by maintaining a minimum distance between portable and mobile RF communications equipment (transmitters) and the Air Carbon Scooter as recommended below, according to the maximum output power of the communications equipment.

Rated maximum output power of transmitter /W	Separation distance according to frequency of transmitter /m		
	150 kHz ~ 80 MHz d = 1.2 P	80 MHz ~ 800MHz d = 1.2 P	800 MHz ~ 2.5 GHz d = 2.3 P
0.01	0.12	0.12	0.23
0.1	0.38	0.38	0.73
1	1.2	1.2	2.3
10	3.8	3.8	7.3
100	12	12	23

For transmitters rated at a maximum output power not listed above, the recommended separation distance d in meters (m) can be estimated using the equation applicable to the frequency of the transmitter, where P is the maximum output power rating of the transmitter in watts (W) according to the transmitter manufacturer.

NOTE 1 At 80 MHz and 800 MHz, the separation distance for the higher frequency range applies.
 NOTE 2 These guidelines may not apply in all situations. Electromagnetic propagation is affected by absorption and reflection from structures, objects and people.

2.5 Choking Hazard

This scooter contains small parts that may pose a choking hazard to young children under certain conditions.

2.6 Using a Lift (Vehicle Mounted)

Lifts are installed in vehicles such as vans and buses, as well as in buildings, to assist users in moving safely between different levels.

- **This scooter is not suitable to use as a seat in a vehicle**
- Ensure user fully understand the lift manufacturer’s operating instructions before use
- Never exceed the lift manufacturer’s specified safe working load or recommended load distribution
- Always switch off the scooter while on the lift
- Failure to do so may result in accidental movement, causing the scooter to roll off the platform — note that the roll-stop may not prevent this
- Confirm that the scooter is in drive mode (not freewheel mode) before using the passenger lift

2.7 Manual Handling

Do not lift the seating system by any removable parts, as this may cause damage to the scooter or result in injury to the user.

2.8 Intended Use

The Royale Air Carbon scooter is designed to provide a smooth and reliable driving experience in both indoor and outdoor environments.

Its compact design and simple construction make it well suited for easy servicing, refurbishment, and recycling.

The Royale Air Carbon is designed to support a wide range of user needs, preferences, and mobility requirements.

2.8.1 Area of Application; The User

Scooters are designed exclusively for individuals who are unable to walk or who have limited mobility, for their personal use both indoor and outdoors.

Operating a scooter requires adequate cognitive, physical, and visual abilities. The user must be capable of assessing and correcting their actions while driving the scooter.

The scooter is intended for a single user only and must not carry more than one person at a time. The maximum weight capacity (120kg) — including the user and any installed accessories — is indicated on the product label attached to the scooter’s chassis.

Before operating the scooter, the user must be familiar with the contents of this manual. Additionally, a qualified specialist must provide thorough instruction before the user participates in public traffic. Initial driving sessions should always be conducted under the supervision of a trained instructor or advisor.

Indications

The Royale Air Carbon Scooter is intended for individuals who are unable to walk or have limited mobility due to:

- Paralysis
- Amputation of a leg
- Deformities or defects of the limbs
- Joint contractures or injuries
- Medical conditions such as heart or circulatory disorders, balance impairments, or cachexia

It is also suitable for elderly users who retain sufficient upper body strength.

Contraindications

The scooter should not be used by individuals who experience:

- Impaired perception or awareness
- Significant balance difficulties
- Inability to maintain a stable seated position

The scooter is mainly composed of front wheels, drive wheels, motor and drive devices, armrest, backrest, seat cushion, battery and charger. The structural diagram is as below.

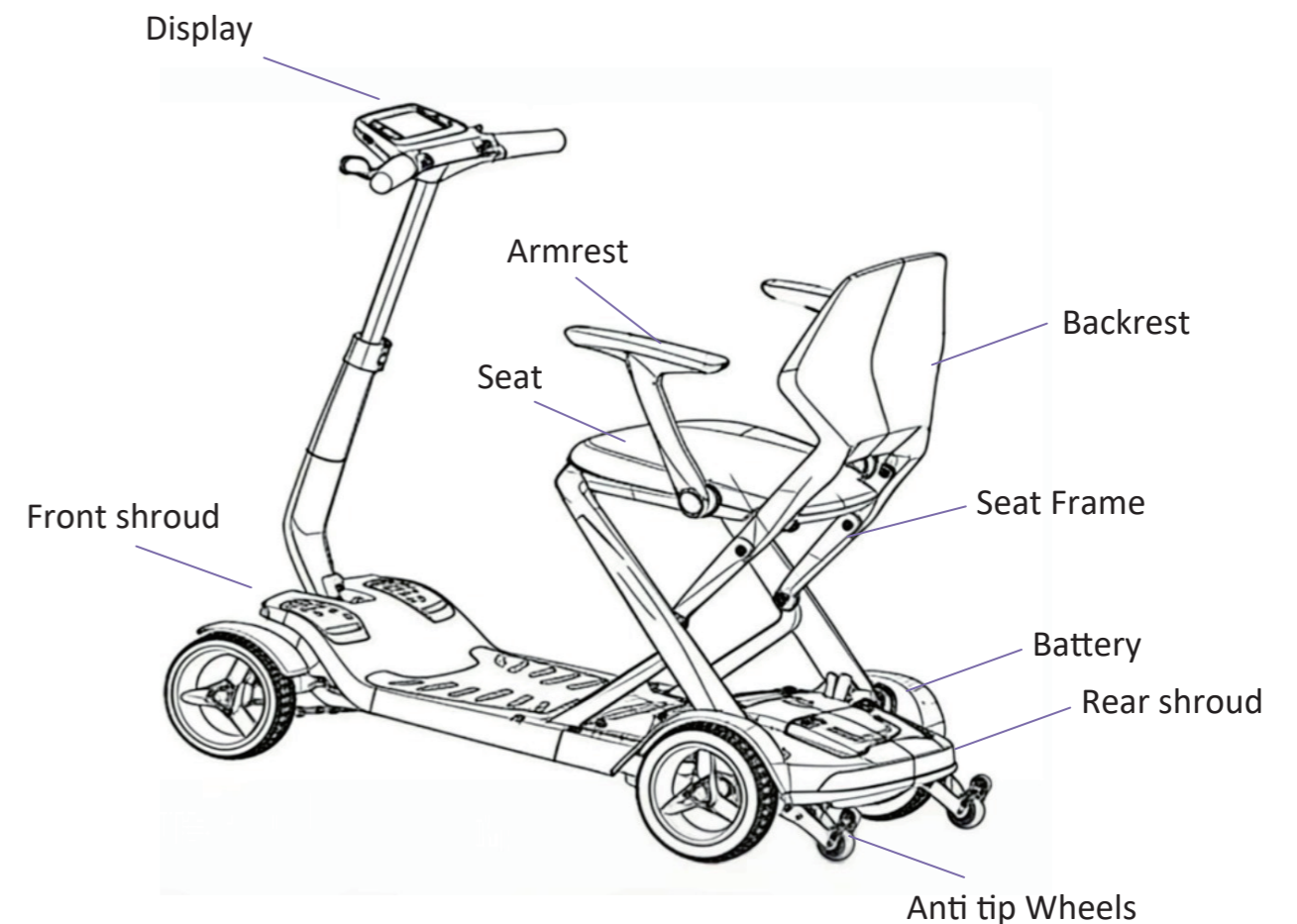

Please note that operating a scooter requires adequate cognitive, physical, and visual abilities. The user must be capable of evaluating their actions while driving and correcting them when necessary. Royale Medical cannot evaluate these abilities or ensure the safe use of any additional components and therefore assumes no liability for any resulting damage.

Always refer to the operating instructions for both the scooter and any attached components. Ensure the user is properly instructed in their safe operation and made aware of all specific warnings that must be read, understood, and followed.

Features 3

Note: Do not operate the scooter if you are under the influence of medication that may affect your ability to drive safely.

- Sufficient vision is essential for the safe operation of the scooter in all situations.
- The scooter is designed for a single occupant only; it must not carry more than one person at a time.
- Children must never use or ride in the scooter without supervision.
- Users must always remain within the Safe Working Load (SWL) specified for the scooter. Exceeding the maximum weight limit — which includes the user and any accessories or carried items — may affect stability, performance, and safety, and could result in equipment damage or personal injury.

The scooter user is fully responsible at all times for adhering to all applicable local safety regulations and guidelines.

2.8.2 Area of Application; The Environment

This scooter is designed for indoor and outdoor use. This scooter has been tested in accordance with AS 3695.2:2019 standard. When used outdoors, it should only be driven on smooth, paved surfaces such as roads, pavements, footpaths, or bicycle paths. Always adjust your speed to match the surrounding conditions and environment.

- Drive cautiously on wet or slippery surfaces caused by rain.
- Do not drive on muddy, rugged, soft, icy surfaces.
- Exercise extra care when driving at higher speeds. Reduce the maximum speed when indoors, on pavements, or in pedestrian areas.
- Avoid driving off high obstacles or curbs.
- Do not attach any additional weight or accessories to the scooter without approval from a qualified specialist, as this may compromise the product's stability.
- Avoid exposing the scooter to sea water, as it is corrosive and may cause serious damage.
- Keep the scooter away from sand, which can enter moving parts and lead to excessive wear.
- Do not operate the scooter in temperatures below -10°C to 50°C.
- Never use the footplate to open doors.
- Do not push, pull, or tow objects with the scooter.
- Avoid driving through puddles or standing water.

- Full carbon fibre frame - reduces overall weight, with high-gloss modern finish
- Ultralight design - for easier lifting and transport
- Quick-fold mechanism - folds in seconds and tows like luggage
- Dual removable lithium batteries - up to 16 km combined range
- Height-adjustable tiller - supports personalised positioning and comfort
- Removable seat cushion - allows for easy cleaning and maintenance
- Front and rear LED lights - improve visibility in low-light conditions
- Flip-up armrests - assist with safer transfers
- NFC card start system - provides controlled access and added security

4 Specifications

Safe Working Load	120 kg
Battery Type	Lithium
Battery Size	6 AH (x2)
Range	16 km (2 batteries) 8 km (1 battery)
Maximum Speed	6 km/h
Maximum Safe Incline	8°
Turning Circle	130 cm
Ground Clearance	2 cm
Obstacle Climbing	5 cm
Assembled Size (W x L x H)	51.7 x 103 x 92 cm
Folded Size (W x L x H)	52.5 x 44.5 x 69 cm
Weight	13.7 kg (without battery) 13.3 kg (without battery and armrest) Each battery weighs 0.8 kg
Seat Width	47 cm
Seat Depth	38 cm
Seat Height	53 cm
Display	Digital
Front Wheels	7"
Rear Wheels	7"

4.1 Drive range

Please refer to the specification tables in this manual for details on energy consumption and maximum drive range.

The maximum driving range of this device is *16km (2 batteries), measured under optimal conditions. Actual performance may vary based on factors such as terrain, inclines, curves, obstacles, driving style, load, and temperature.

For extended trips or longer distances, we recommend the following:

- Fully charge the battery before use
- Plan your route to avoid steep slopes and obstacles
- Maintain a steady speed and avoid frequent or abrupt stops

Note: The scooter is supplied with two 6Ah batteries. One battery powers the scooter while the second battery is stored beside it under the seat as a spare. When the active battery is depleted, replace it with the stored battery. Each battery must be charged individually using the charging port located on top of the battery.

4.2 Driving on a Slope

The Royale Air Carbon scooter has been designed and tested for safe operation on slopes or gradients of up to 8°.

Note: In certain situations, your scooter may become unstable.

- Before attempting to climb or descend a slope or kerb, use caution when shifting your body weight for balance.
- To improve stability when travelling uphill, lean forward and keep the seat and backrest in an upright position.
- When going downhill, sit upright or slightly recline the seat to maintain balance.
- If you are uncertain about the scooter's ability to safely handle a slope or kerb, do not attempt it - find an alternative route instead.
- Stopping distances on slopes can be significantly longer than on level ground.

4.3 Obstacles & Kerbs

The Royale Air Carbon Scooter's maximum obstacle or kerb climbing height of 50mm.

- Never descend a kerb while travelling backwards.
- Do not attempt to climb or descend steps or use escalators. Doing so is unsafe and may cause injury or damage to the scooter.
- For users with limited upper body stability, it is recommended to use appropriate restraint systems to maintain an upright posture when ascending or descending ramps, kerbs, or obstacles.

Climbing small kerbs/surface lips

- Always approach kerbs at a 90° angle, driving slowly and steadily.
- Stop the scooter as soon as the castor wheels contact the kerb.
- Apply steady power to the motors to lift the front of the chair onto the kerb, then slightly increase power to allow the drive wheels to climb smoothly.
- Keep the handle as straight as possible throughout the manoeuvre.

Descending small kerb/surface lips:

- Always approach kerbs at a 90° angle, driving slowly and steadily.
- Move the scooter slowly and carefully forward until both front wheels are positioned at the edge of the kerb, maintaining a 90° angle to it.
- Descend the kerb slowly and smoothly with the drive wheels — do not stop while moving down. You may feel more secure by leaning slightly backward, but even if you cannot, the scooter remains stable within its designed limits.

5.1 Assembling the scooter

Folding and unfolding the scooter

Folding the Scooter

1. Pull up the latch located underneath the seat. This will unlock the scooter and allow it to begin folding.
2. Place one hand on the front of the tiller bar and the other on the backrest, then gently push both inward until the scooter is fully folded.

Unfolding the Scooter

1. Press the latch down and begin pushing the tiller outward to start unfolding the scooter.
2. Continue pushing the tiller outward until the scooter is fully unfolded and locked into position.

Interchanging the Battery:

Press and hold the battery unlock button with one hand. Using the other hand, grasp the battery handle and pull the battery straight upward to remove it.

Insert the spare battery into the battery slot and push it down firmly until it locks into place. A click sound will indicate that the battery is securely installed.

Tiller adjustment:

Pull the tiller lock clip to unlock the tiller. Adjust the tiller to the desired height, then secure it by locking the clip back into place.

Rotating the Armrest:

The armrest can be rotated upward or downward to assist with compact folding of the scooter or easier transfers on and off the scooter.

To adjust the armrest, press the clip located on the outer edge of the armrest to release the lock. While pressing the clip, rotate the armrest up or down to the desired position. Once positioned, ensure the armrest is securely set before operating the scooter.

Warning - Pinch Hazard:

Keep hands and fingers clear of moving parts and hinge areas while folding or unfolding the scooter, adjusting tiller and armrest as pinch points may cause injury.

5.2. Battery

The scooter is supplied with two 6Ah batteries. One battery powers the scooter while the second battery is stored beside it under the seat as a spare. When the active battery is depleted, replace it with the stored battery. Each battery must be charged individually using the charging port located on top of the battery.

Before first use, fully charge the new battery to ensure it reaches about 90% of its optimal performance. After each use, recharge the battery fully and operate the scooter again - after four to five full charge cycles, the battery will reach near 100% efficiency, helping to extend its lifespan. Recommended charge time is 3-5 hours.

When a battery no longer holds a charge, purchase and install a new battery as needed. Always replace the scooter battery with compatible, manufacturer-approved batteries to ensure safe operation, optimal performance, and compliance with warranty conditions. Ensure the old batteries are appropriately recycled and disposed to prevent environmental pollution.

If the scooter will not be used for an extended period, it is recommended to charge the battery every two weeks and run the scooter for at least 20 minutes to maintain battery health.

Do not charge the battery outdoors. Keep it away from open flames and heat sources while charging. Always charge the scooter in a clean, dry, and well-ventilated area, free from flammable, explosive, or chemical substances.

All replaced or discarded batteries must be recycled or disposed of according to local regulations.

Each battery needs to be charged separately. To charge open the protective cover of the charging port to fully expose the socket. Connect the charger plug directly to the battery's charging port to begin charging.

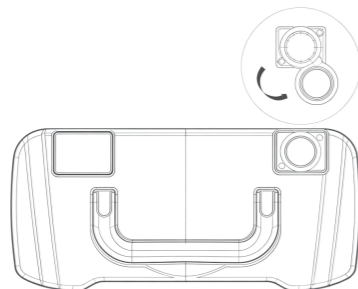

Interchanging the Battery:

Press and hold the battery unlock button with one hand. Using the other hand, grasp the battery handle and pull the battery straight upward to remove it.

Insert the spare battery into the battery slot and push it down firmly until it locks into place. A click sound will indicate that the battery is securely installed.

Battery Care

The following battery care recommendations have been developed in cooperation with battery manufacturers to help users achieve the best performance and longest lifespan from your maintenance-free batteries. Failure to follow these guidelines may result in reduced battery performance and shorter operating range.

- Each battery needs to be charged separately.
- Use only the approved charger that is compatible with your scooter.
- Charge the batteries every night, regardless of how much the scooter has been used during the day.
- Always charge in a well-ventilated area.
- Do not interrupt the charging cycle once it has started.
- For long-term storage (over 15 days), fully charge the batteries, then disconnect the main battery lead.
- Failing to regularly recharge the batteries may cause permanent damage, reduced travel distance, and early battery failure.
- Do not “top up” or partially charge the batteries during the day — wait until evening for a full overnight charge.
- Following these steps will help ensure healthier batteries, greater travel range, and a longer overall battery life.

Using the Charger

The battery charger is an essential part of the scooter, allowing for quick and efficient charging to achieve a full battery. The external charger has been designed to charge the Lithium-Ion battery.

The chargers are equipped with safety features designed to prevent accidents or damage caused by incorrect battery connection, overheating due to faults, or attempts to charge batteries of the wrong voltage.

To charge the battery:

- Each battery needs to be charged separately.
- Ensure the scooter is turned off and the rechargeable battery is properly connected to it.
- Insert the three-pin metal plug of the charger into the three-hole socket on the battery.
- Plug the other end of the charger into a standard electrical outlet. The red light indicates charger is connected to the power source, orange charging is in progress, and the green light shows that the battery is fully charged.
- Once charging is complete, disconnect the charger and power cable.
- Never attempt to open, modify, or tamper with the batteries under any circumstances. If you have any concerns, contact your local authorised Royale Medical dealer for assistance.
- Do not leave the batteries or battery pack unattended while charging.

As with all mains-powered electrical equipment, always replace blown fuses with a fuse of the same type and rating as specified.

- Using an incorrect fuse type may increase the risk of fire, cause damage to the charger, or prevent it from functioning properly.

5.3 Operating the scooter

All the drive control for the scooter can be found on the console at the top of the tiller.

LCD Display

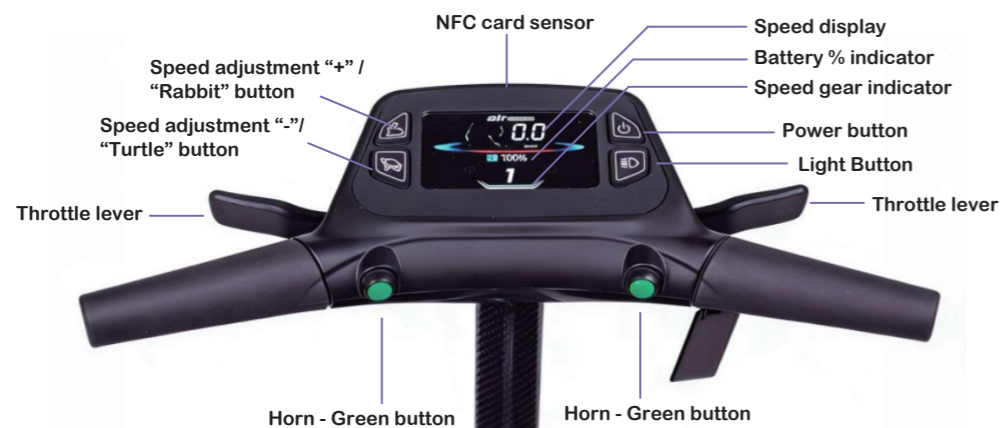

- NFC card sensor
NFC card sensor is located at the front of the scooter where “Royale” logo is located. Swipe your NFC card to power on or off the scooter

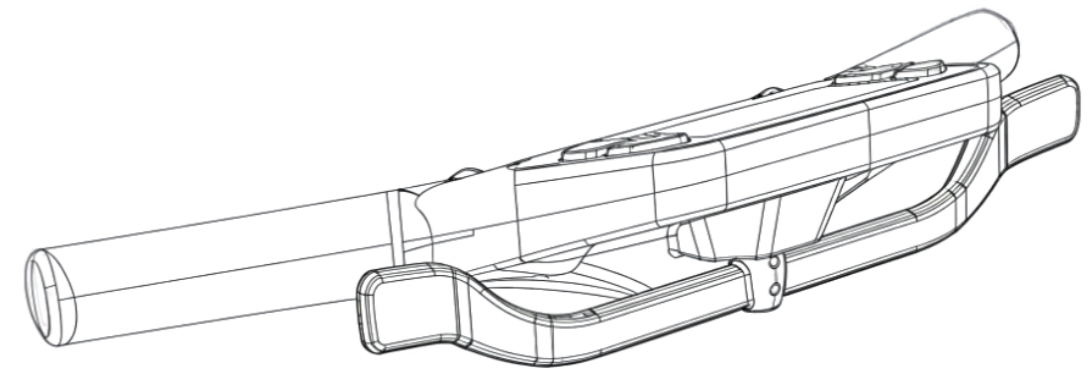

- Throttle lever
Pull the right wig-wag lever to drive forward.
Pull the left wig-wag lever to reverse.
- Adjusting the speed:
Press the “rabbit” to increase the speed setting by one level (maximum level 5)
Press “turtle” to decrease the speed setting by one level (minimum level 1)
- Horn button
Press the green button to activate the horn.
- Power button
Press the power button to turn off the scooter.
- Light button
Press the light button to activate the light at the front of the scooter.

Note: Manual on when the NFC card is lost
To manual unlock the scooter press the following buttons once.

1. Light button
2. Turtle button
3. Rabbit button
4. Power button

Please refer to the button sequence shown below.



Note: When using the button sequence to turn on the scooter, the recognition time is **10 seconds**. The buttons must be pressed in the correct order within this time for the scooter to power on.

5.4 Freewheel Mechanism

A freewheel device disengages the power drive to allow manual operation (i.e. the mobility scooter can be manually pushed)

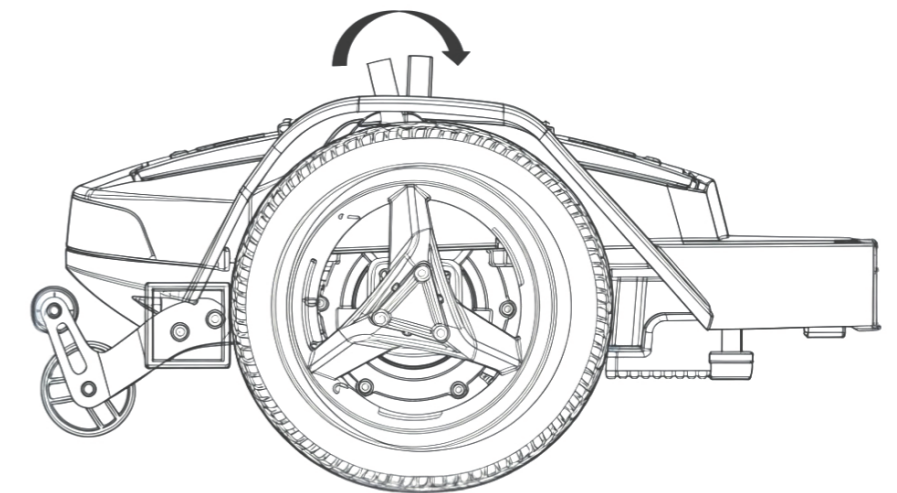

To move the scooter manually, flip the red brake release levers located at the rear, above the anti-tip wheels to unlock position. This feature is designed to serve as an emergency freewheel release mechanism.

Only release the brake levers when the scooter is on a flat surface and the power has been turned off, or in case of an emergency. After manually moving the scooter with the brakes released, flip the brake release levers to re-engage and lock the brakes.

Be aware that when the brakes are released, the scooter can move freely, increasing the risk of accidents.

Do not operate the brake release levers with your feet, as this may cause them to bend, break, or become inoperable.

6 Transporting the Scooter

6.1 Air Transportation

The Royale Air Carbon Scooter and the 24V6AH Lithium-Ion battery are recommended for air transport.

Note: Please be advised that airline carriers have varying policies with respect to flying with Lithium-Ion powered items.

ILS recommend the 24V6AH sized lithium battery for any airline travel with your Royale Air Carbon scooter, however, please confirm with your airline carrier prior to arranging travel. The airline carrier ultimately confirms or denies travel of any Lithium device, and specification requirements onboard.

If your airline accepts the scooter and the battery, it is recommended to follow the steps below to prepare your scooter for air transport:

- Ensure the battery charge does not exceed 40%. Refer to battery indicator on display screen.
- Disconnect the battery from compartment.
- Fold the scooter.
- Pack the scooter carefully in its original packaging or with the travel bag accessory for safe transport.

6.2 Vehicle Transportation

Fold the scooter and place it securely in the boot of the vehicle for transport. Ensure that no objects are placed on top of the scooter, as this may cause damage.

6.3 Using your scooter on the Train

Before travelling by train, please contact the train operator for information on any specific requirements or instructions. It is recommended to confirm the following before your journey:

- Whether there is a designated scooter/wheelchair area on the train with adequate turning space for safe manoeuvring.
- Whether there is a suitable or marked area on the platform for scooter/wheelchair users, also allowing sufficient space to manoeuvre.

- That boarding access is suitable for both entering the train carriage and reaching the designated scooter/wheelchair area.
- That the boarding ramp or lift can safely support the combined weight of the scooter and occupant.
- That the slope of the boarding access does not exceed the scooter's maximum safe gradient.
- That any obstacles or thresholds on the platform or train do not exceed the scooter's maximum kerb-climbing height.

Most train operators can aid with scooter users, but this usually needs to be arranged in advance.

We recommend keeping your user manual available when planning your trip and when contacting the train operator.

7 Labelling Information

The device has a product label. The product label includes the following information:

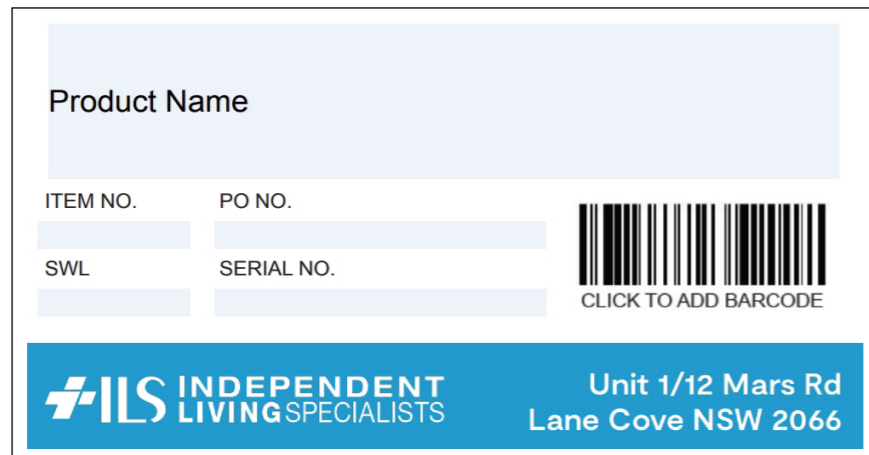

- Name and address of the company
- Name and code for the product
- Safe Working Load (SWL)
- Serial number of the product (which includes the date of manufacture and the batch serial number)

Product Care & Maintenance 8

The lifespan of your scooter depends greatly on appropriate maintenance and care.

For details regarding specific adjustments, maintenance, or repair services, please contact your authorised Royale Medical dealer. When doing so, always provide the model, year of manufacture, and the serial number found on the product label.

It is recommended that your scooter is serviced by an authorised Royale Medical dealer at least once a year, or every six months if it is used intensively.

To find a list of approved dealers in your area, please contact your Royale Medical Dealer.

8.1 Maintenance

Loose fasteners should be tightened according to the installation instructions.

- If any broken or loose components are found, stop using the scooter immediately and contact your authorised Royale Medical dealer for replacement parts.
- Check all components to ensure they adhere properly when pressed together.
- Remove any debris, such as fluff or hair, from components, as this can reduce their holding strength.

If you have any concerns or uncertainties about your scooter's performance requirements, please contact your authorised Royale Medical dealer for guidance.

- After carrying out any maintenance or repairs, always ensure the scooter is operating correctly before use.

- All fasteners must be replaced with identical parts that match the original length, tensile strength, and material specifications.
- When replacing self-locking nuts or fasteners that use a thread-locking compound, make sure to reapply an appropriate thread-locking solution before installation.

8.2 Daily Checks Before Use

Perform the following routine checks before operating the scooter each day:

Checking front and rear wheels

- Ensure that all wheels are securely fastened.

Checking the battery

- Before using your scooter for the first time, charge the batteries to 100%.
- Check that the batteries are adequately charged — the green lights on the battery indicator should be illuminated.

Checking the freewheel lever

- Make sure the freewheel lever is set to the “drive” position.

Checking the seat, backrest and armrest

- Ensure that the seat cushion is properly positioned and secure. Backrest and armrest are upright and in correct position.

Checking the console

- Check all the buttons on the console are working.

Checking for clothing entrapment risk

- When operating the scooter, make sure your clothing does not interfere with its movement (e.g. garments that are too long).
- Before use, check that your clothing and accessories are clear of the wheels and any other moving or rotating parts where they could become caught or entangled.

Checking weather conditions

- In cold weather, battery performance decreases. During mild frost, capacity drops to about 75% of normal, and at temperatures below -5°C, it may reduce to around 50%. This will limit the scooter’s driving range.
- Ensure operation is within environmental temperature requirements.
- Plan trips prior to avoid exposure to wet weather.

9 Recycling & Disposal

Please follow the local government rules regarding proper recycling and disposal. Recycling and disposal should always be done through an authorised agent or licensed place of disposal.

Please review the list of scooter parts and packaging materials to ensure they are recycled or disposed of correctly.

- Frame - Carbon fibre, steel and plastic
- Wheels - Polyurethane
- Motors - Aluminium, steel and copper
- Seat - Polyurethane
- Packaging - Cardboard carton and plastic
- Battery - Lithium-Ion

Please follow the local government rules in regard to the proper disposal and recycling.

Trouble Shooting 10

If the scooter is not functioning properly, review the following checklist:

- Ensure the batteries are fully charged.
- Turn the Scooter off, then switch it back on.
- Confirm that all battery is locked and secured in it's place.
- Check that the freewheel lever is set to the drive position.

10.1 Trouble shooting guide

Symptom	Possible Cause	Solution
Shortened range	Batteries not charged for long enough	Charge batteries for eight hours or more
	Batteries weak and cannot hold charge	Replace battery pack
Battery pack not charging or battery gauge shows empty after charging	Battery pack fault	Replace charger
	Charge fault	Contact local mobility dealer
	Charger loom or plug damaged	Check plugs and looms
	Loose connection	Try a wall socket in a different room
	No output from wall outlet	Unplug from wall & change fuse
	Fuse in charger mains plug blown	Switch off and press button back in
	Button on battery pack has popped out	Switch off and press button back in
Output fuse in charger blown	Unplug from wall and contact dealer	

Battery charging current high	Faulty batteries	Replace battery pack
	Scooter switched on during charging	Turn Scooter off
Unable to drive	Brake-release lever disengaged	Engage brake-release lever
	Flat batteries	Charge battery pack
	Scooter is not switched on with key	Ensure the key is switched on
Unable to drive	Battery pack not engaged properly	Check battery pack is fully engaged onto connectors
	Charger plugged in	Unplug charger
	Button on battery pack popped out	Reset circuit-breaker button
	Disconnected loom or plugs	Check all plugs & looms
	Control system fault	Contact dealer
Motor runs irregularly and/or noisily	Electrical malfunction	Contact dealer
	Control system fault	Contact dealer
DO NOT ATTEMPT TO OPEN ANY PARTS OF THE SCOOTER CONTROL SYSTEM, BATTERY PACK, LOOMS, PLUGS OR BATTERY CHARGER. THE CONTROL SYSTEM IS SAFETY CRITICAL AND THERE ARE NO USER SERVICEABLE PARTS		

10.2 Error Codes and Troubleshooting

The scooter is fitted with a self-diagnostic controller that provides a sequence of audible beeps when an error is detected. These beep sequences help you, or an authorised service agent, identify potential faults within the drive electronics.

If you switch on the scooter and hear a series of beeps, count the number of beeps in each sequence. The sequences are separated by a short pause. Refer to the table below to identify the corresponding error code and recommended action.

Number of beeps	Represents	Possible Cause	Solution
1	Battery power low	Power not enough	The battery needs charging
2	Low Battery voltage	Power not enough	The battery needs charging
3	High battery voltage	Too higher voltage, while overloading or climbing	Decrease speed while climbing
			Check battery connection
4	Electric current over limit	Electric current over limit of motor	Check motor and relative wiring connections Switch off and wait a few minutes and Switch on
5	Freewheel level issue	The freewheel level is on	Check the relative wiring of the freewheel level
			Confirm the level is on the correct position
6	Accelerate the variable resistor issue	When turning on the controller, accelerate variable resistor isn't on the neutral position	Make sure the accelerate variable resistor is on the neutral position Accelerate variable resistor may need to recalibration.
7	Speed limited variable resistor issue	Accelerate variable resistor, Speed limited variable resistor or other wiring issue	Check all the accelerate variable resistor, Speed limited variable resistor or other wiring
8	Motor voltage issue	Motor and other relative wirings issue	Check Motor and other relative wirings
9	Other issues	Some inner issues in the controller	Check all the connection and wirings
10	Pushing / Slipping issues	The speed of pushing or slipping is over limited	Switch off and on the controller

11 Warranty

Warranty Coverage

If any part of this product requires repair or replacement due to a manufacturing or material defect within 24 months of purchase, the affected component(s) will be repaired or replaced free of charge.

- This warranty covers manufacturing defects only.

How to Make a Warranty Claim

To make a warranty claim, please contact the authorised dealer from whom you purchased your Scooter.

All warranty repairs must be carried out by an authorised dealer.

Repaired or Replaced Parts

Any part repaired or replaced under this warranty will remain covered for the remainder of the original warranty period for the product, as outlined in 'Warranty Coverage'.

Electronics And Batteries

The electrical components and batteries supplied with this product are covered under the manufacturer's warranty for a period of 12 months from the date of purchase. This warranty covers defects in materials or workmanship.

The warranty for batteries applies only when the batteries have been used, charged, and stored in accordance with the instructions provided in this manual.

Batteries must be charged using the approved charger supplied.

The warranty becomes void if the batteries are damaged due to:

- Improper charging or use of non-approved chargers.
- Over-discharge or neglect (e.g., leaving batteries uncharged for extended periods).
- Exposure to extreme temperatures, fire, or water.
- Physical damage or tampering.

Refer to 5.2 battery information and manufacturers recommendations.

Warranty Exclusions

This warranty does not cover repairs or replacements required as a result of:

- Normal wear and tear (including but not limited to batteries, armrest pads, upholstery, tyres, etc.).
- Overloading the product beyond its maximum user weight (refer to the product label).
- Failure to maintain or service the product as recommended in the user or service manual.
- Use of accessories not approved or supplied as original parts.
- Damage caused by neglect, accident, misuse, or improper handling.
- Modifications or alterations that deviate from the manufacturer's specifications.
- Repairs undertaken without prior authorisation from ILS Customer Service.

Governing Law

This warranty is subject to the laws of the country in which the product was originally purchased.

Product Life Expectancy

The estimated life expectancy of this product is five years, provided that:

- It is used strictly in accordance with the intended use described in this manual.
- All maintenance and service requirements are completed as recommended.

With proper care and maintenance, this lifespan may be extended. However, extreme or incorrect usage can significantly reduce it.

- The stated life expectancy is an estimate only and does not constitute an additional warranty.

If you have any questions regarding the use, maintenance, or safety of your scooter, please contact your local authorised Royale Medical dealer.

If you are unsure of an approved dealer in your area or have additional inquiries, please contact us by phone or in writing at the details below:

Independent Living Specialists Pty Ltd

Unit 1/12 Mars Road, Lane Cove, 2066, NSW

Phone: 1300 008 267

www.ilsau.com.au

12 Battery Material Safety Data Sheet (MSDS)

		Page 1 of 10	Report No.: CCJC2512109R02
Material Safety Data Sheet			
<h2>MSDS 报告</h2> <h2>MSDS Report</h2>			
申请商: Prepared For:	东莞市博贝斯新能源科技有限公司 Dongguan Bobes New Energy Technology Co., Ltd.		
地址: Address:	广东省东莞市横沥镇新四黄塘路 89 号 3 号楼 301 室 3rd Floor, Building D, Guangdong Huayuzhi Industrial Park, 89 Huangtang Road, Hengli Town, Dongguan City, China		
产品名称: Product Name:	锂离子电池组 Li-ion Battery Pack		
型号: Model:	BBS 2406-3		
参数: Parameters:	24V, 6.4Ah, 153.6Wh		
质量: Weight:	Approx(约). 1050.38g		
尺寸: Dimension:	75mm×110mm×226mm (T×W×L)		
编制单位: Prepared By:	深圳诚测检测技术有限公司 Shenzhen CCJC Technology Co., Ltd. 广东省深圳市宝安区松岗街道溪头社区溪头路25号厂房101 (1-3层) 1-3/F., Factory 101, No.25, Xitou Road, Xitou, Songgang Street, Bao'an District, Shenzhen, Guangdong, China		
报告编号: Report No.:	CCJC2512109R02	接收日期: Accepted date:	2025-03-10
检验日期: Inspection Date:	2025-04-10	生效日期: Effective Date:	2025-04-10
主检人: Tested by:	李远勇 Li Yuan Yong	批准人: Approved by:	程鹏 Roc Cheng
职位 Position:	测试工程师 Test Engineer	职位 Position:	技术负责人 Technical Manager
审核人: Inspected by:	钟庭芝 Tosha Zhong	签发日期: Date of Issue:	2025-04-10
职位 Position:	项目工程师 Project Engineer		

		Page 2 of 10	Report No.: CCJC2512109R02
Material Safety Data Sheet			
第一部分 化学品及企业标识 Section 1 - Chemical Product and Company Identification			
产品名称: Product Name:	锂离子电池组 Li-ion Battery Pack		
产品型号: Product Model:	BBS 2406-3		
制造商: Manufacture:	东莞市博贝斯新能源科技有限公司 Dongguan Bobes New Energy Technology Co., Ltd.		
地址: Address:	广东省东莞市横沥镇新四黄塘路 89 号 3 号楼 301 室 3rd Floor, Building D, Guangdong Huayuzhi Industrial Park, 89 Huangtang Road, Hengli Town, Dongguan City, China		
电话: Tel:	+86-769-88086182		
传真: Fax:	/		
应急电话: Emergency Tel:	+86-769-88086182		
邮箱: E-mail:	894915476@qq.com		
第二部分 危险性概述 Section 2 - Hazards Identification			
危险性类别 Classification of Danger	见第十四部分。 See section 14.		
浸入途径 Primary Route(s) of Exposure	眼睛, 皮肤接触, 摄入。 Eye, skin contact, ingestion.		
健康危害 Health Hazard	正常条件下根据制造商的说明使用电池不会产生危害。使用不当的情况下, 有破裂、起火、发热、内部成分泄漏的危险, 并可能造成意外损失。使用不当的行为包括但不限于下列情况: 长时间充电、短路、投入火中、硬物撞击、尖物刺破、破碎, 和破裂。 The batteries are not hazardous when used according to the instructions of manufacturer under normal conditions. In case of abuse, there's risk of rupture, fire, heat, leakage of internal components, with could cause casualty loss. Abuses include but not limited to the following cases: charged for long time, short circuited, put into fire, whacked with hard object, punctured with acute object, crushed, and broken.		
第三部分 成分/组成信息 Section 3 – Composition/Information on Ingredients			

Page 3 of 10
Report No.: CCJC2512109R02

化学名称 Chemical Composition	CAS 编号 CAS No.	浓度或浓度范围(%) Concentration or concentration ranges (%)
镍钴锰酸锂 Nickel-cobalt-manganese lithium	346417-97-8	30.9
石墨 Graphite	7782-42-5	17.5
聚偏氟乙烯 PVDF	4937-79-9	0.3
羧甲基纤维素 CMC	9000-11-7	0.2
乙炔黑 Acetylene black	1333-86-4	0.3
丁苯橡胶 Styrene-butadiene rubber	9003-55-8	0.6
聚丙烯 PP	9003-07-0	0.7
六氟磷酸锂 Lithium hexafluorophosphate	21324-40-3	2.2
碳酸乙烯酯 Ethylene carbonate	96-49-1	2.2
碳酸甲乙酯 Ethyl methyl carbonate	623-53-0	1.3
碳酸二甲酯 Dimethyl carbonate	616-38-6	7.9
铜 Copper	7440-50-8	12.5
铝 Aluminum	7429-90-5	5.0
镍 Nickel	7440-02-0	0.7
铁 Iron	7439-89-6	17.7

标签根据EC指令。
 Labeling according to EC directives.

不需要象形符号和危险短语。
 No symbol and risk phrase are required.

注意: CAS 号是化学文摘服务注册号码。
 Note: CAS number is Chemical Abstract Service Registry Number.

N/A = 不适用。
 N/A=Not apply.

Page 4 of 10
Report No.: CCJC2512109R02

第四部分 急救措施
 Section 4 - First Aid Measures

眼睛 Eye	万一接触，立即用大量的清水冲洗至少15分钟，翻起上下眼睑，直到化学的残留物消失为止，迅速就医。 Flush eyes with plenty of water for at least 15 minutes, occasionally lifting the upper and lower eyelids. Get medical aid.
皮肤 Skin	万一接触，用大量水冲洗至少15分钟，同时除去污染的衣物和鞋子，迅速就医。 Remove contaminated clothes and rinse skin with plenty of water or shower for 15 minutes. Get medical aid.
吸入 Inhalation	立即从暴露处移至空气清新处，如果呼吸困难给予输氧，立即就医。 Remove from exposure and move to fresh air immediately. Use oxygen if available.
食入 Ingestion	饮用至少两杯牛奶或水。如果当事人仍然清醒可以采取催吐的方法，并且立即就医。 Give at least 2 glasses of milk or water. Induce vomiting unless patient is unconscious. Call a physician.

第五部分 消防措施
 Section 5 - Fire Fighting Measures

危险特性 Characteristics of Hazard	高密度粉尘遇空气会形成爆炸性混合物。燃烧生成有毒烟雾。 Dusts at sufficient concentrations can form explosive mixtures with air. Combustion generates toxic fumes.
燃烧产生的危险物品 Hazardous Combustion Products	二氧化碳。 Carbon dioxide.
灭火方法及灭火剂 Fire-extinguishing Methods and Extinguishing Media	对于小型火灾，可使用水枪，干冰（也就是液态二氧化碳）或化学泡沫。 For small fires, use water spray, dry chemical, carbon dioxide or chemical foam.
灭火注意事项 Attention in Fire-extinguishing	因为压强关系，要穿戴可呼吸式全身防护装备，MSHA/NIOSH（经认证或等效的），以及佩戴全套防护装置。 Wear self-contained breathing apparatus in pressure-demand, MSHA/NIOSH (approved or equivalent) and full protective gear.

第六部分 泄露应急处理
 Section 6 - Accidental Release Measures

个人防护措施、防护装备和应急程序 Personal Precautions, protective equipment, and emergency procedures	万一破裂。注意！腐蚀性物质。避免接触皮肤，眼睛或衣服。确保空气流通。根据需要使用个人防护装备。将人员撤离到安全区域。让人们远离溢出/泄漏处和处于上风。参考第七部分和第八部分中列出的防护措施。 In case of rupture. Attention! Corrosive material. Avoid contact with skin, eyes and clothing. Ensure adequate ventilation. Use personal protective equipment as required. Evacuate personnel to safe areas. Keep people away from and upwind of spill/leak. Refer to protective measures listed in Sections 7 and 8.
环境保护措施 Environmental Precautions	防止产品污染土壤和进入下水道或水道。 Prevent product from contaminating soil and from entering sewers or waterways.
方法和材料控制 Methods and materials for Containment	出于安全，阻止泄漏，可以用干砂或泥土来遏制液体溢出，立即清理溢出物。 Stop the leak if safe to do so. Contain the spilled liquid with dry sand or earth. Clean up spills immediately.



清理的方法和材料 Methods and materials for cleaning up	用惰性吸收剂(干砂或泥土)吸收溢出的材料。污染物转移到可接受的废物容器中。收集所有受污染的吸收剂,按照第十三部分的说明进行处理。用洗涤剂和水清洁污染区域,收集所有受污染的洗涤水,妥善处理。 Absorb spilled material with an inert absorbent (dry sand or earth). Scoop contaminated absorbent into an acceptable waste container. Collect all contaminated absorbent and dispose of according to directions in Section 13. Scrub the area with detergent and water; collect all contaminated wash water for proper disposal.
---	--

第七部分 操作处置与储存
Section 7 - Handling and Storage

操作 Handling	拆解、挤压、直接放入火中或高温条件下,电池可能发生爆炸和燃烧。禁止短路或将电池正负极错误的安装在设备中。 In case of rupture. Handle in accordance with good industrial hygiene and safety practice. Avoid contact with skin, eyes or clothing. Use personal protection equipment.
储存 Storage	储藏于阴凉,干燥,通风处,远离接触会发生反应的材料。存储锁定。放在儿童无法接触的地方。 Store in a cool, dry, well-ventilated area away from incompatible substances. Store locked up. Keep out of the reach of children.
其他要注意的防范措施 Other Precautions	万一破裂。按照良好的工业卫生和安全规范进行操作。避免接触皮肤,眼睛或衣服。使用个人防护设备。 The battery may explode or cause burns, if disassembled, crushed or exposed to fire or high temperatures. Do not short or install with incorrect polarity.

第八部分 接触控制和个体防护
Section 8 - Exposure Controls/Personal Protection

工程控制 Engineering Controls	保证空气流通使空气密度保持在低水平。如果在会生成微粒的情况下使用,应仔细观察3mg/m ³ ACGIH TLV-TWA 的吸入量(总量为10mg/m ³)。 Use adequate ventilation to keep airborne concentrations low. If used under conditions that generate particulates, the ACGIH TLV-TWA of 3mg/m ³ respirable fraction (10mg/m ³ total) should be observed.
个人防护设备 Personal Protective Equipment	眼睛和脸部保护:消费者无需使用。如果有接触危险:密封安全护目镜。面部防护罩。 Eye and Face Protection: None required for consumer use. If there is a risk of contact: Tight sealing safety goggles. Face protection shield. 皮肤和身体防护:消费者无需使用。如果有接触危险:穿戴防护手套和防护服。 Skin and Body Protection: None required for consumer use. If there is a risk of contact: Wear protective gloves and protective clothing. 呼吸系统防护:正常使用条件下不需要防护设备。如果超过暴露限值或发生刺激,可能需要通风和疏散。 Respiratory Protection: No protective equipment is needed under normal use conditions. If exposure limits are exceeded or irritation is experienced, ventilation and evacuation may be required.

第九部分 理化特性



Section 9 - Physical and Chemical Properties

物理状态 Physical State	外形:棱柱形 Appearance: Prismatic 颜色:黑色 Color: Black 气味:泄漏时,医用乙醚的气味。 Odour: If leaking, smells of medical ether.
变化的条件 Change in condition	
酸碱度 pH	不适用。 Not applicable as supplied.
熔点/凝固点 Melting point/freezing point	不适用。 Not applicable as supplied.
沸点、初沸点和沸程 Initial boiling point and boiling range	不适用。 Not applicable as supplied.
闪点 Flash Point	不适用。 Not applicable as supplied.
爆炸极限 Explosion Limits	不适用。 Not applicable as supplied.
蒸气压 Vapour pressure	不适用。 Not applicable as supplied.
蒸气密度 Vapor density	不适用。 Not applicable as supplied.
密度/相对密度 density/Relative density:	不适用。 Not applicable as supplied.
溶解性 Solubility	不适用。 Not applicable as supplied.
n-辛醇/水分配系数 Partition coefficient: n-octanol/water	不适用。 Not applicable as supplied.
自燃温度 Auto-ignition temperature	不适用。 Not applicable as supplied.
分解温度 Decomposition temperature	不适用。 Not applicable as supplied.
气味阈值 Odour threshold	不适用。 Not applicable as supplied.
蒸发速率 Evaporation rate	不适用。 Not applicable as supplied.
易燃性(固体、气体) Flammability (solid, gas)	不适用。 Not applicable as supplied.

第十部分 稳定性和反应性
Section 10 - Stability and Reactivity

化学稳定性 Chemical Stability	稳定的。 Stable.
-----------------------------	-----------------

Page 7 of 10 Report No.: CCJC2512109R02	
危险反应的可能性 Possibility of Hazardous Reactions	不适用。 Not Available.
应避免的条件 Conditions to Avoid	火焰、火花和其他火源，不相容的材料。 Flames, sparks, and other sources of ignition, incompatible materials.
不相容材料 Incompatible materials	氧化剂、酸、碱。 Oxidizing agents, acid, base.
有危害分解物 Hazardous Decomposition Products	一氧化碳、二氧化碳、氧化锂烟雾。 Carbon monoxide, carbon dioxide, lithium oxide fumes.
第十一部分 毒理学信息 Section 11 - Toxicological Information	
刺激 Irritation	内部物质暴露的情况下，蒸汽烟雾可能对眼睛和皮肤的刺激性。 In the event of exposure to internal contents, vapour fumes may be very irritating to the eyes and skin.
致敏 Sensitization	不适用。 Not Available.
再生毒性 Reproductive Toxicity	不适用。 Not Available.
协同材料毒理学 Toxicologically Synergistic Materials	不适用。 Not Available.
第十二部分 生态学信息 Section 12 - Ecological Information	
通用信息: General note:	不允许未稀释或大量的产品接触地下水、水道或污水处理系统。 Do not allow undiluted product or large quantities of it to reach ground water, water course or sewage system.
化学产品在环境/可能的环境预期的行为的一种生态毒性 Anticipated behavior of a chemical product in environment/possible environmental impact/ ecotoxicity	不适用。 Not Available.
第十三部分 废弃处置 Section 13 - Disposal Considerations	
废弃处置方法 Waste Treatment	建议遵照国家和地方法规处置或再利用。 Recycle or dispose of in accordance with government, state & local regulations.

Page 8 of 10 Report No.: CCJC2512109R02	
废弃注意事项 Attention for Waste Treatment	废电池不能被当作普通垃圾。不能扔进火中或置于高温下。不能解体，刺穿，破碎或类似的处理。最好的处理办法是回收利用。 Deserted batteries couldn't be treated as ordinary trash. Couldn't be thrown into fire or placed in high temperature. Couldn't be dissected, pierced, crushed or treated similarly. Best way is recycling.
第十四部分 运输信息 Section 14 - Transport Information	
UN 编号 UN number	UN3480 or UN3481
运输专用名称 Proper shipping name	锂离子电池（包括锂离子聚合物电池）或 Lithium ion batteries (including lithium ion polymer batteries) or 与设备包装在一起的锂离子电池（包括锂离子聚合物电池）或 Lithium ion batteries packed with equipment (including lithium ion polymer batteries) or 内置在设备中的锂离子电池（包括锂离子聚合物电池） Lithium ion batteries contained in equipment (including lithium ion polymer batteries)
危险货物类别 Class or division	9
海洋污染物（是/否） Marine pollutant (Yes/No)	否 No
包装等级 Packing group	I
备注 Comment	包装必须达到 II 级包装的性能标准 Packagings must meet packing group II performance standard
无论是对内还是对外的运输或运输方式，用户都需要注意或遵守的特殊预防措施。 Special precautions which a user needs to be aware of, or needs to comply with, in connection with transport or conveyance either within or outside their premises	
国际民用航空组织/国际航空运输协会: ICAO / IATA:	货物可根据民用航空组织(ICAO), TI或国际航空运输协会(IATA), DGR 66 th (2025版)包装说明(PI)965 Section IA或PI 966 Section I 或PI 967 Section I 相关规定进行空运。 Can be shipped by air in accordance with International Civil Aviation Organization (ICAO), TI or International Air Transport Association (IATA), DGR Packing Instructions (PI) 965 Section IA, or (PI) 966 Section I, or (PI) 967 Section I appropriate of IATA DGR 66 th (2025 Edition) for transportation.
国际海运危险货物规则: IMDG CODE:	该电池受IMDG Code 2024 版(Amdt 42-24)限制,包装说明P903. Can be shipped by sea in accordance with IMDG Code 2024 Edition (Amdt 42-24) Packing Instructions P903.
此外，每个锂电池和电池组类型都必须通过联合国《关于危险货物运输的建议书 试验和标准手册》第38.3 节规定的适用测试 In addition, to be permitted in transport each lithium cell and battery types must have passed the applicable tests set out in Subsection 38.3 of the UN Manual of Tests and Criteria.	



第十五部分 法规信息
Section 15 - Regulatory Information

- a) 《危险物品规则》
Dangerous Goods Regulations
- b) 联合国《关于危险货物运输的建议书 规章范本》
Recommendations on the Transport of Dangerous Goods-Model Regulations
- c) 联合国《关于危险货物运输的建议书 试验和标准手册》
Recommendations on the Transport of Dangerous Goods-Manual of Tests and Criteria
- d) 《国际航空运输协会》(IATA)
International Air Transport Association (IATA)
- e) 《国际海运危险货物规则》(IMDG)
International Maritime Dangerous Goods (IMDG)
- f) 《危险货物安全运输技术指南》
Technical Instructions for the Safe Transport of Dangerous Goods
- g) 《危险货物分类和品名编号》- GB 6944-2012
Classification and code of dangerous goods (GB 6944-2012)
- h) 2012《职业安全与健康标准》危险通信标准 (29 CFR 1910.1200)
2012 OSHA Hazard Communication Standard (29 CFR 1910.1200)
- i) 《有毒物质控制法》(TSCA)
Toxic Substance Control Act (TSCA)
- j) 《联邦条例》
Code of Federal Regulations
- k) 符合所有联邦、州和地方法律
In accordance with all Federal, State and local laws

第十六部分 其他信息
Section 16 - Other Information

本份 MSDS 中的信息只是基于我们当前所拥有的相关材料的信息而编制的，只是为了描述本品的健康、安全与环境需求，以使各有关方面能更好地了解和信任本产品。这些信息只是提供给您，以供考虑、研究和确认。其中的一些危害预防措施描述并非唯一的。所以本份 MSDS 不能作为使用本品实现任何特定目的的保证。各有关使用者有责任预先完成本品的安全性及其他方面的测试，以评判其是否满足您的使用目的。

To the best of our knowledge, the information contained herein is accurate. However, neither the above named supplier nor any of its subsidiaries assumes any liability whatsoever for the accuracy or completeness of the information contained herein. Final determination of suitability of any material is the sole responsibility of the user. All materials may present unknown hazards and should be used with caution. Although certain hazards are described herein, we cannot guarantee that these are the only hazards that exist.

本文所包含的数据/信息已经过审核和批准，但本文档不包含出口管制信息。
The data/information contained herein has been reviewed and approved for general release on the basis that this document contains no export controlled information.

样品图片:
Sample photo:

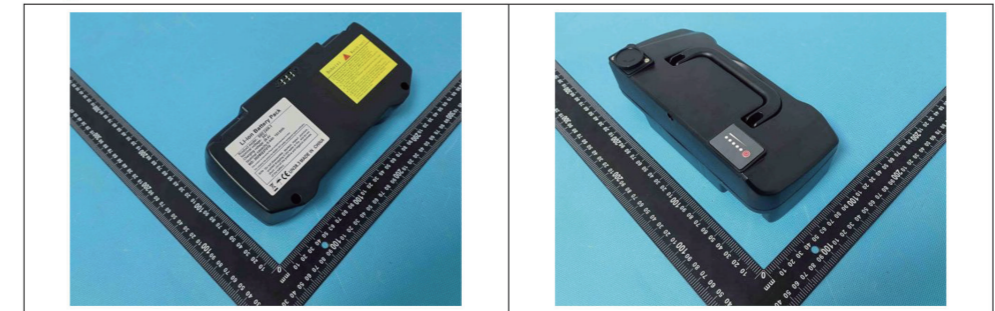

--报告结束--
--End of report--





Independent Living Specialists

Unit 1, 12 Mars Road

Lane Cove West NSW 2066

1300 008 267 | ilsau.com.au

©2023 ROYALE MEDICAL. INDEPENDENT LIVING SPECIALISTS

PDT037-0424