

ELATA[®]

AIR CUSHION AND PUMP

User Manual

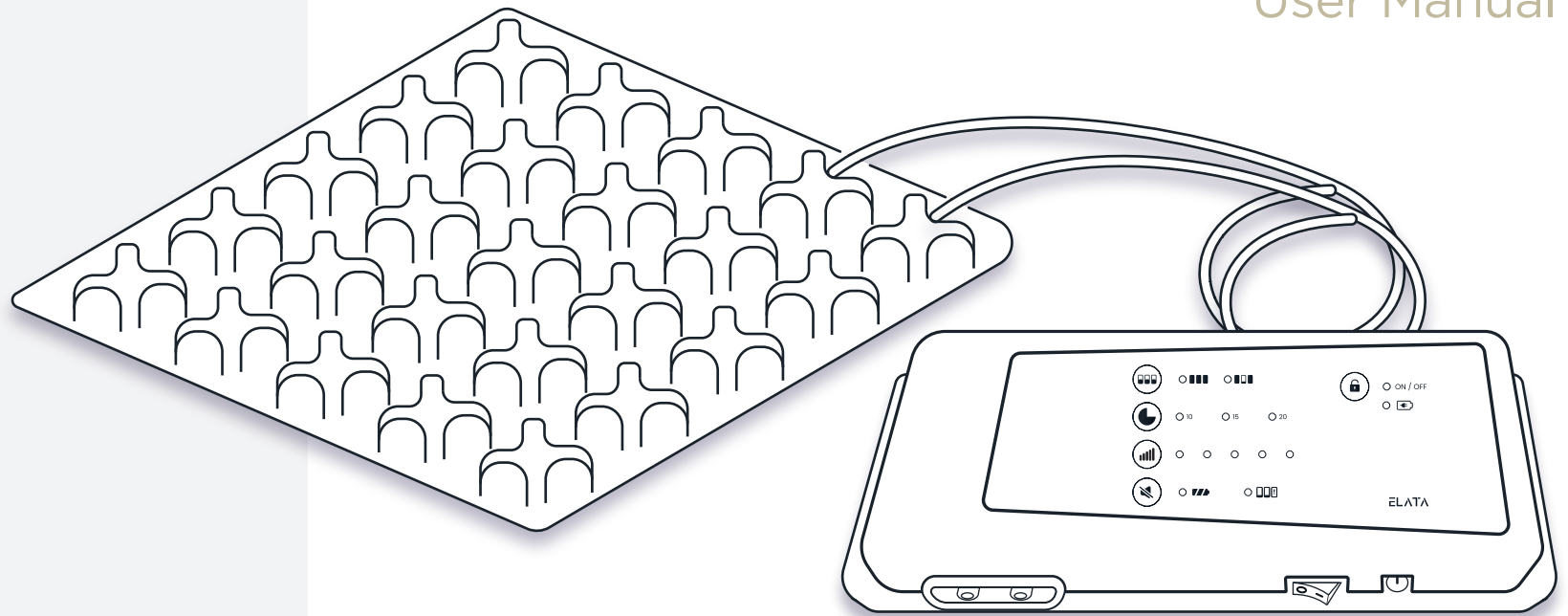

ENA-M0001C

CONTENT

Notice to users	4
Intended use	5
Indications, contra-indications, general and suitability	6
Model Numbers and Compatibility	7
Specifications for the Pump	8
General Safety Instructions	8
Before Use	11
Fitting Elata® Air Cushion	12
Product Functions	15
Battery fitting and operation of the pump	17
Troubleshooting	18
Maintenance	18
Cleaning	19
Storage and Transport	20
Product Disposal	20
Warranty	20
Table of Symbols	21

Welcome

Dear Customer, thank you for purchasing an Enable Lifecare product. Before operating the Elata® Air Cushion system, you must read and understand all the instructions in this manual. All actions and handling of the product must be performed in accordance with the instructions in this manual.

Please ensure that the manual is available to users and operators throughout the product service life. If you need further information, please contact us.

Notice to User

If a serious incident occurs in relation to this medical device affecting the user or patient, please report it to Enable Lifecare Pty Ltd.

2 Selgar Avenue, Tonsley SA 5042 | 1300 370 370 | support@enablelifecare.com.au

Design Policy and Copyright

Configura® and Configura™ are trademarks belonging to Accora Ltd unless otherwise stated. © Accora Ltd 2025. Elata® And Elata™ are trademarks belonging to Enable Lifecare Pty Ltd unless otherwise stated. © Enable Lifecare Pty Ltd 2025.

1. INTENDED USE

The Elata® Air Cushion system is a powered alternating air cushion designed to reduce the risk of patients developing pressure damage.

Regular alternation of the cushion cell pressure reduces the impact of pressure on parts of the body which may be susceptible to pressure damage. The alternation stimulates blood flow which can help to heal skin tissue. An alternating air cushion must only be used following professional assessment by a clinician or healthcare professional of the patient's condition.

This guidance should be used in conjunction with regular monitoring of the patient's pressure care requirements. Note that there are many factors which influence the risk of developing pressure damage and a cushion is just one possible intervention. A holistic approach must be used when assessing the pressure needs of a patient.

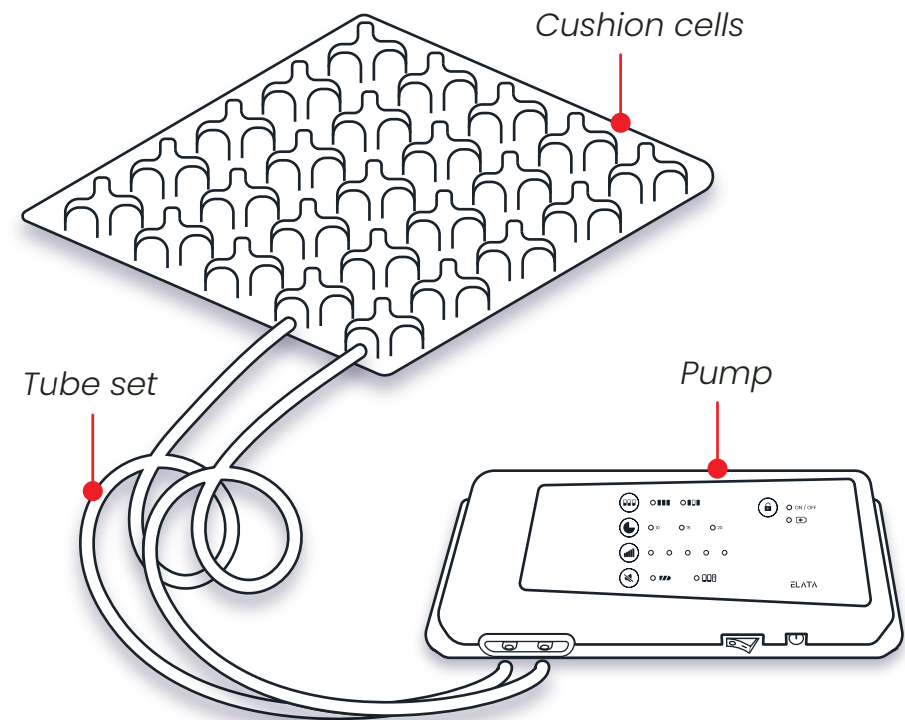

The illustration shows some key features of the Elata® Cushion/ Elata® Bariatric Air Cushion and the Elata® Air Cushion Pump

Indications for Use

The Elata® Air Cushion system is suitable for use in the following areas:

- Long term medical care where medical supervision is required, and monitoring is provided if necessary. e.g. nursing homes and geriatric facilities.
- A domestic area. i.e. home healthcare.

General

The Elata® Air Cushion system consists of the Elata® Cushion/Elata® Bariatric Air Cushion, an alternating air cushion and the Elata® Air Cushion Pump. The Elata® Air Cushion Pump is mains-powered with backup battery-power. The Elata® Air Cushion system must only be used with Accora™ Configura chairs as recommended by Enable Lifecare. See Section 2 – Model Numbers and Compatibility for part numbers and compatibility.

Contra-Indications (not appropriate for):

- Patients with demanding pressure care requirements.
- If patients have conditions that may be affected by moving or alternating services, clinical advice must be sought before use.

The Air Cushion System is suitable for:

- Patients up to a maximum mass of 160kg (when used with E600C) or 220kg (when used with CA2725).
- Patients at risk of pressure injury.
- For prevention and management of pressure damage (subject to professional assessment by a clinician).
- Ambulant, semi-ambulant and non-ambulant patients.

NOTE: If existing pressure damage does not improve or the patient's condition changes, the overall therapy solution must be reviewed by a clinical professional. These are guidelines and must not replace clinical judgement.

2. MODEL NUMBERS AND COMPATIBILITY

MODEL	DESCRIPTION	COMPATIBILITY
E600C	Elata® Air Cushion	Suitable for use with: <ul style="list-style-type: none"> • Accora™ Configura Advance • Accora™ Configura Comfort Provided with power supply cable and bag for pump
EP-C	Elata® Air Cushion Pump	
CA2400	Elata® Air Cushion and Pump (kit)	
CA2478	Elata® Bariatric Air Cushion	Suitable for use with the following models of Accora™ Configura Bariatric Chairs: CR5470, CR5471, CR5472, CR5473, CR5474, CR5475, CR5476, CR5477, CR5478. <i>Note that the maximum patient weight for the Elata® Bariatric Air Cushion is 220kg</i>
E600CB	Kit consisting of the Elata® Bariatric Cushion (CA2748), Configura Bariatric Overlay (CA2803) and Elata® Air Cushion Pump (EP-C)	

Replacement parts

MODEL	DESCRIPTION	COMPATIBILITY
SC2655	Battery	Replacement battery for ELATA® Air Cushion Pump (EP-C)
SC2656	Power supply cable	Replacement Power supply cable for ELATA® Air Cushion Pump (EP-C)
SC2654	Pump bag	Replacement pump bag for ELATA® Air Cushion Pump (EP-C)
SC2424	Air tubing	Replacement tubing for ELATA® Air Cushion (E600C)

3. SPECIFICATIONS FOR THE PUMP

DESCRIPTION	SPECIFICATIONS
Adaptator	AC 100- 240V, 50/60Hz; 2A; 3W
Li battery	11.1V 2200MAH
Weight	Pump: 1110g; Adapter: 310g
Dimensions	24 X 12.4 X 7.2 cm
Air output	4 liter/min
Pressure Range	38 - 120mmHg

DESCRIPTION	SPECIFICATIONS
Operating Temperature	10°C – 35°C
Storage Temperature	(-50°C) – (50°C)
Shipping Temperature	(-15°C) – (50°C)
Operation Humidity	20% - 80% non-condensing
Storage Humidity	10% - 90% non-condensing
Shipping Humidity	10% - 90% non-condensing

4. GENERAL SAFETY INSTRUCTIONS

- Before using the Elata® Air Cushion system, you must read this manual and use the device in accordance with it. This device may only be operated by people who are able to operate in accordance with the manual.
- The Elata® Air Cushion system must not be used if faults have been detected that may injure the patient or nearby person or damage nearby equipment.
- A clinical assessment and risk assessment must be carried out by suitably trained and qualified personnel before the Elata® Air Cushion system is used.
- The Elata® Air Cushion system must be set-up/configured by suitably trained and qualified personnel after a clinical assessment and risk assessment has been carried out.

General Warnings

This is an electrical item and should be treated with caution. Do not place extra layers between the patient and the seat cushion. It can potentially reduce the benefits provided by the cushion.

To reduce the risk of electric shock:

- Always unplug the pump after use.
- Do not use the cushion while bathing.
- Do not place or store the cushion or pump where it could fall into water.
- Do not place the cushion or pump in any liquid or water.
- Do not touch the cushion or pump if it has fallen into water. Unplug it immediately.



Specific warnings

- Do not use the cushion or pump in the presence of flammable objects, chemicals or oxygen rich environments as this may cause an explosion.
- Due to the risk of electric shock, do not attempt to open the pump. If repairs are required, please contact Enable Lifecare.
- Enable Lifecare shall not be held liable for any damage, injuries or accidents arising from negligence or use that is at variance with this manual.
- Follow the safety features and instructions for operating this product.

- Do not modify this product.
- Before using this product ensure the patient is familiar with its functionality.
- Only use the Elata® Air Cushion system with chairs authorised by Enable Lifecare. Only trained service personnel should perform maintenance on the cushion.
- Do not allow children to play on or with the cushion. Take extra care when using the system with the children present.
- Be aware of any potential fire hazards. Patients must not smoke when using the cushion. Do not move the chair if the pump power supply cable is connected.
- The cushion is intended for indoor use only.
- Never place the cushion power cable under the chair.
- Do not cover the pump as it may get warm during use.
- Avoid spillage of liquids and water on the electrical system.
- Use this product only for its intended use or as described in the manual. Do not use attachments not recommended by Enable Lifecare.
- Never operate this product if it has a damaged cord or plug, is not working properly, has been dropped or damaged, or has fallen into water. Return the product to Enable Lifecare for examination and repair.
- Never block the air openings of this product or place it on a soft surface, such as a bed, where openings may be blocked. Always use metal extender legs, where required.

- Do not use where aerosol spray products are being used.
- Placing extra layers between the patient and the cushion potentially reduces the benefits provided by the cushion and should be avoided or kept to a minimum.
- Only use the pump supplied with the cushion, or a replacement supplied by Enable Lifecare.

General Protection

- Protect from the elements.
- Use only on a level debris free surface.



5. BEFORE USE

- The Elata® Air Cushion system must not be used until it has been set-up and configured by suitably trained and qualified personnel after a clinical assessment and risk assessment has been carried out.
- Ensure that the pressure control on the pump is adjusted in line with the assessment recommendation.
- Do not allow the user to sit in the chair until the air cells have fully inflated.
- If an existing cushion system is being replaced with the Elata® Air Cushion system, the setup of the chair must be checked to ensure it is appropriate for the user.
- If the chair is transferred to a new user, the Elata® Air Cushion system must be removed, and a new assessment carried out by a clinician on the new patient's pressure needs.
- Do not use the Elata® Air Cushion system if air is leaking from any of the cells.
- Do not place the pump power cable under the chair or where it may be pinched, squashed or damaged by the chair or other equipment.
- Do not smoke when sitting on the Elata® Air Cushion system.

Carry out the following checks before first use and at regular intervals during use:

- Ensure the Elata® cushion is fitted correctly in the seat base.
- Check that the tube set does not stretch or snag when the chair is operated through a full cycle.
- Plug the power cable into a power socket and switch the socket on.
- Switch on the pump and check that the cells inflate correctly.
- Check that the pump pressure setting has been set by a qualified clinician/healthcare professional, or as per the assessment.
- Make sure Elata® cushion is fully inflated.
- The cushion is ready for use if all the above checks are satisfactory, and no problems are detected.

6. FITTING ELATA AIR CUSHION

Warning:

Installation must be carried out by a competent person.

The Elata® Air Cushion system must not be used until it has been set-up and configured by suitably trained and qualified personnel after a clinical assessment and risk assessment has been carried out.

Steps:

Fit the Elata® Air Cushion as follows:

1. Remove the bottom back pillow (Configura Comfort chair shown in Figure 1.1).
2. For the Elata® Air cushion: Unzip the overlay cover at the back of the overlay and fold back the cover to expose the foam cushion (Configura Comfort chair shown in Figure 2.1). For the Bariatric Air Cushion: Remove the overlay from underneath the seat base and from the sides of the seat cushion by unzipping the cover. Release the Velcro from underneath the chair, the sides of the cushion and the leg rest.
3. For the Elata® Air Cushion: The foam cushion is attached to the overlay by a single dotted cut line

at the front of the cushion only. Carefully pull the foam cushion away from the front of the overlay down the dotted line. Be careful not to rip the foam at the front to the overlay. Remove the foam cushion from the overlay. For the Elata Bariatric Air Cushion: Put on the new overlay provided with the Elata Bariatric Air Cushion kit. Replace the overlay starting from the legrest, then underneath the seat base, then the sides of the cushion. It is easier to access the Velcro fastening underneath the seat base if the backrest is removed. When fitting, always ensure that the overlay is secure on the Velcro fastening tabs.

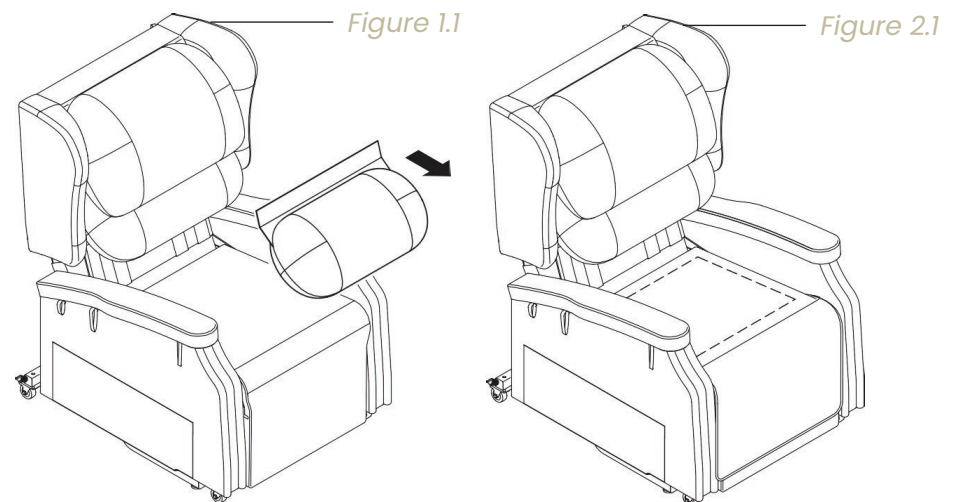

4. Remove the foam cushion from the overlay.
5. For the Elata® Air Cushion and Elata® Bariatric Air Cushion: Insert the Air Cushion into the overlay. Make sure that the cells of the Air Cushion face upwards and the tube set is fed out of the back of the chair through the opening in the foam on the patient's left-hand side (as seen when sitting in the chair)
6. Ensure the tube set exits on the back of the chair on the users left side when seated in the chair (Configura Comfort chair shown in Figure 6.1a and 6.1b).

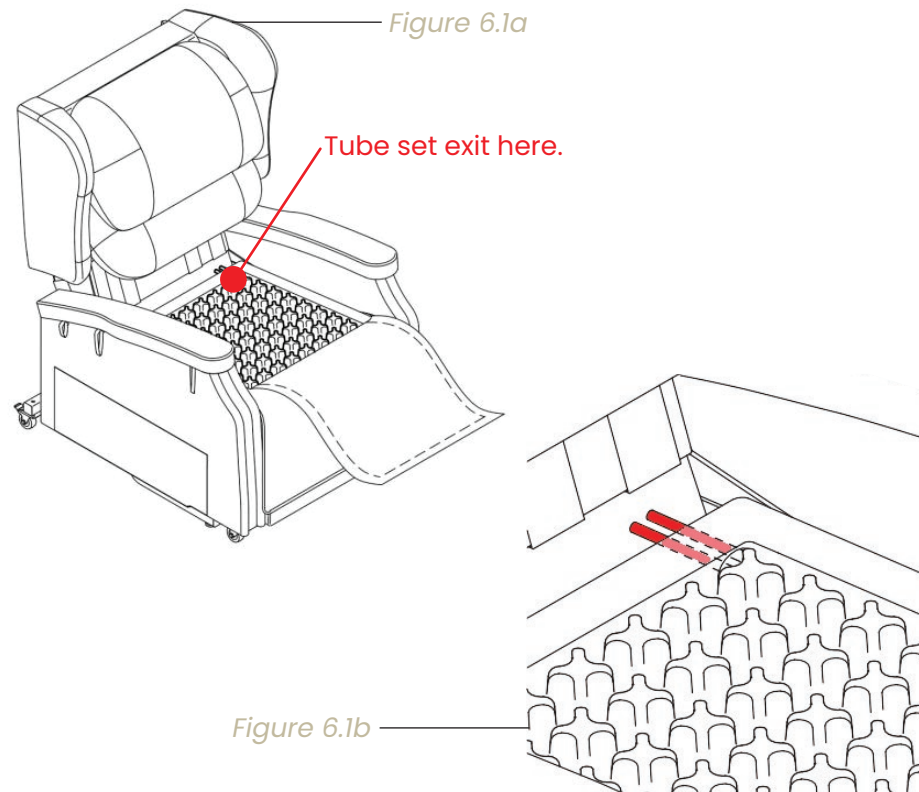

7. Reassemble the chair by zipping the double headed zip up to the pipe on both sides and refitting the lower cushion (Configura Comfort chair shown in Figure 7.1).

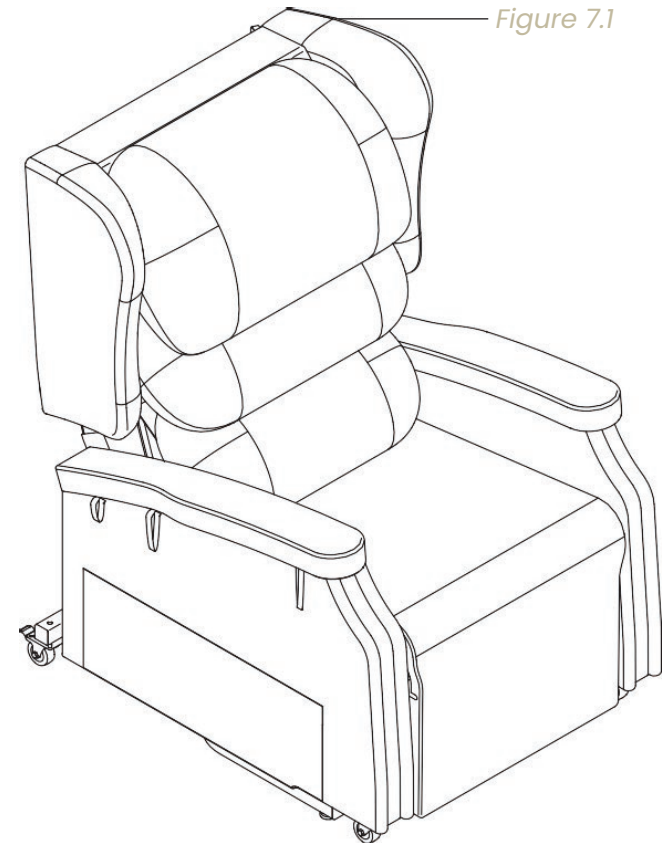

8. Operate the chair through a full cycle to ensure that no cables or tubes are snagged, kinked or trapped when operating the chair:

Configura Comfort

(Figure 8.1a). The tube set must be routed alongside the backrest fitting bracket (1), above tube (2) and secured with the Velcro hook and loop fixing (3).

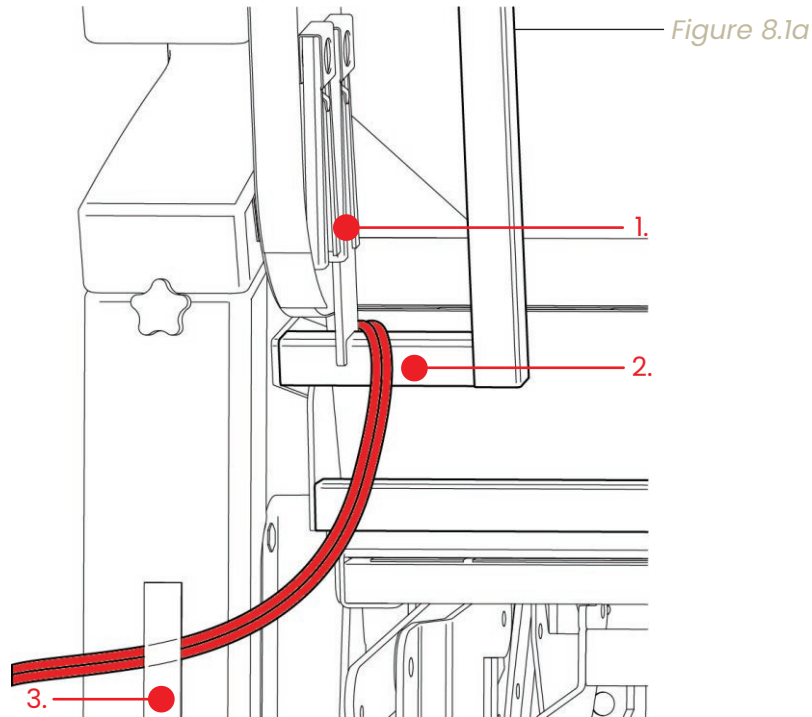

Configura Advance

(Figure 8.1b). The tube set must be routed alongside the backrest fitting bracket (1), above tube (2) and then secured to the chair sidepiece (3) with the Velcro hook and loop fixing. Operate the chair through a full cycle to ensure that no cables or tubes are snagged, kinked or trapped when operating the chair.

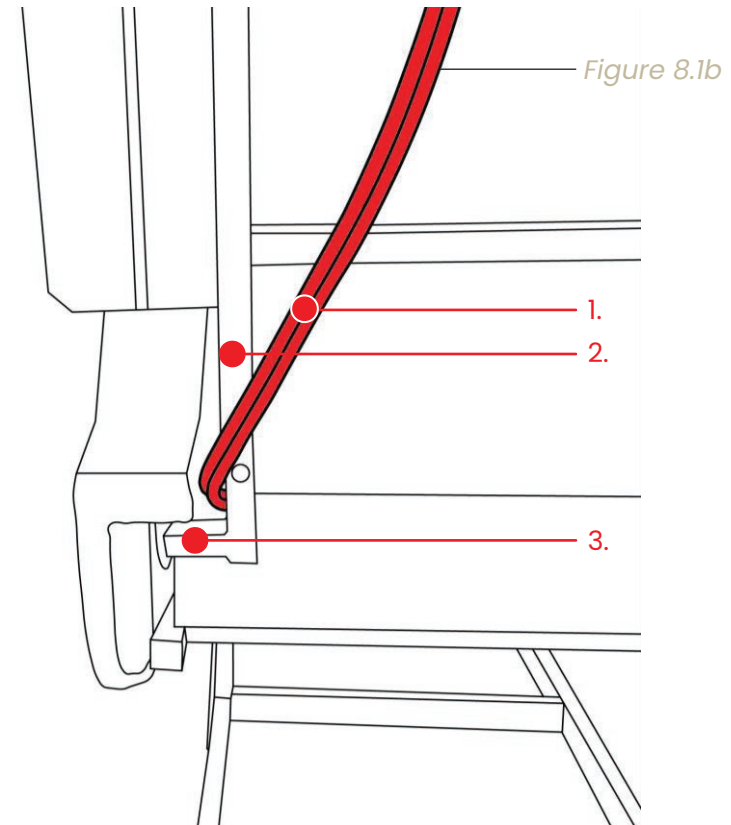

7. PRODUCT FUNCTIONS

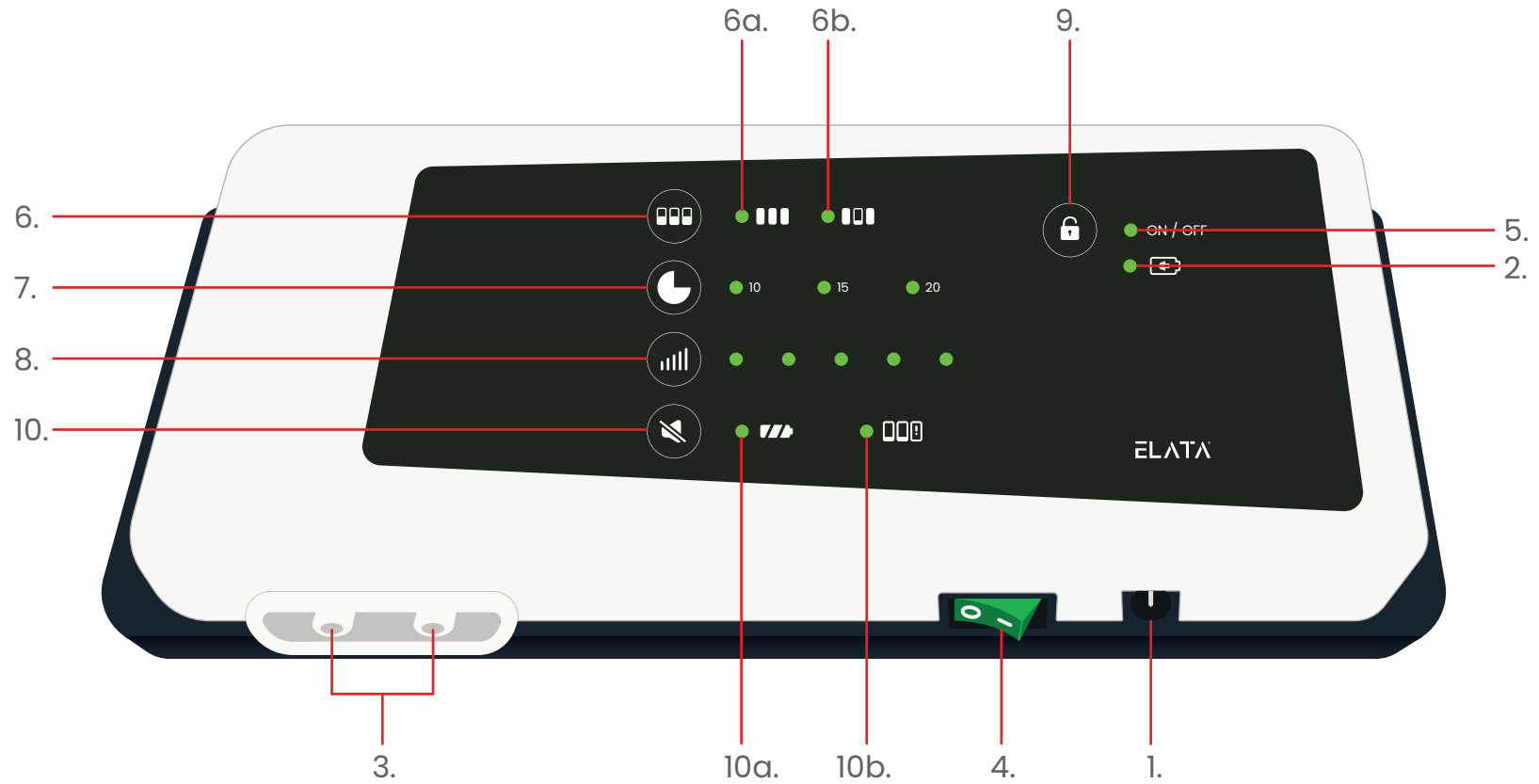

● Light Indicator

Functions:

1. Power Supply Cable inlet: the charging adaptor inlet to insert the adapter connector.
2. Battery Charging indicator: yellow light comes on when the battery is being charged.
3. While charging is in progress, the battery charging indicator [2] will light up. Charge the battery till [2] is no longer lighted. You can keep the pump plugged in if you are using a stationary chair.
4. Power switch: press the power switch to turn the pump on or off.
5. Power Indicator:
 - Yellow light comes on when power switch is switched on.
 - When Start/Stop key is pressed, green light comes on.
6. Mode Selection Key: press this key to toggle between
 - a. Static mode
 - b. Alternating mode.
7. Cycle time selection Key:
 - a. Alternating cycle time of 10 min
 - b. Alternating cycle time of 15 min
 - c. Alternating cycle time of 20 min
8. Pressure setting Key: Pressure can be increased by pressing the key. The current pressure is shown by indicator lights from 1–5. See the following table for recommended pressure settings based on approximate user weight. It is recommended to start

at the pressure setting closest to the user's approximate weight, and then adjust it lower or higher based on their comfort.

Pressure Setting	1	2	3	4	5
Approx. User Weight	<70kg	80kg	90kg	100kg	220kg

9. Start/Stop Key
10. Mute key
 - a. Low Battery warning indicator
 - b. Low Pressure warning indicator

Warning:

Do not use the Elata® Air Cushion with any other pump. Using an incompatible pump can result in damage to the cushion and/or inefficient therapy.

There are no user-serviceable components within the pump. Do not attempt to disassemble or service the pump. If there is a need for replacement, or repair, always contact service technicians authorised by Enable Lifecare Pty Ltd.

Battery fitting:

1. Unscrew the battery cover (back of the pump) and slide the cover open.
2. Plug the battery connector plug into the battery connector socket. Push the connectors to ensure firm connection.
3. Install the battery.
4. Slide the battery cover closed and make sure it is firmly snapped into position.
5. Secure the battery cover with the screw.

Operation of the pump:

1. Connect the power supply cable to the power supply cable inlet [1] on the pump.
2. Plug the power supply cable to an in-wall AC outlet.
3. While charging is in progress, the battery charging indicator [2] will light up. Charge the battery till [2] is no longer lighted. Disconnect the power supply cable from the pump before unplugging from the in-wall AC outlet.
4. Connect the charged pump to the Elata® Air Cushion at inflation nozzles [3]. Ensure both tubes are firmly connected at [3].
5. Switch on the pump using power switch [4]. The power indicator [5] should light up.
6. Select mode using the mode selection key [6]. Choose between the following modes:

- **Alternating Cycle time mode:** The odd and even numbered cells inflate and deflate alternatively to change the contact area where the patient is supported. The user may choose to alternate quicker or slower by changing the cycle time between 10min, 15mins or 20mins using key [7].
 - **Static mode:** All cells are inflated equally to give the patient even support.
7. The user can vary the softness or hardness of the Elata® Air Cushion using key [8] to choose between 5 pressure settings.
 8. Once the mode, time and pressure settings have been selected, start the therapy by pressing the Start/Stop key [9] for 2 seconds. The power indicator light [5] should turn green.
 9. The mode, cycle time and pressure can be adjusted at any time using the respective keys [7-9].
 10. The pump will beep if the battery level or air pressure in the cushion is low and the corresponding visual alarm indicator will light up. Refer to the "Troubleshooting" section for more information. To mute the audible alarm, press the "Mute" key [10].

8. TROUBLESHOOTING

If the pump does not work:

- Check if the battery capacity is too low: Charge the battery and try again. If the pump still does not work, contact Enable Lifecare Pty Ltd.

In case alarm rings:

- Check if the cushion tubes are properly connected to the inflation nozzles.
- Re-route if there are any kinks.
- Check connectors between air cushion and pump for loose connections or broken air tubes.

9. MAINTENANCE

Warning:

Maintenance must be carried out by a competent person.

Do not use the Elata® Air Cushion system if the patient, maintenance person, carer or another person is aware of any malfunction or incorrect performance.

If the patient is not comfortable with the Elata® Air Cushion system, contact the clinician or clinical prescriber.

Maintenance for all Elata® Air Cushion systems:

We recommend the Elata® Air Cushion system is checked weekly. If any damage is detected, inform the clinician or healthcare professional and take the cushion out of service.

- Check the power supply cord/battery charger cord for any damage, abrasions or excessive wear.
- Check the pipe set for any damage, abrasions, excessive wear or kinks.
- Check both pipes in the tube set are correctly fitted to the pump and to the cushion and routed correctly to avoid being snagged, kinked or pinched.
- Check the cushion cells are correctly fitted to the chair and the cushion cells and cover are not excessively worn or damaged.
- Check the pump is working as expected without unexpected noise or heat.
- Check the tube set is not snagged, kinked or pinched when the chair is operated through a full cycle.

General Protection

- Protect from the elements.
- Use only on a level debris free surface.

10. CLEANING

Warning:

Cleaning must be carried out by a competent person. When cleaning the cushion, use protective clothing such as gloves and aprons. Infection could be transmitted from user to user if the chair is reused, or from user to carer or cleaner.

Before cleaning the cushion unplug the pump mains cable/charging cable from the socket. Avoid spillage of liquids while cleaning the product. Do not allow excess cleaning solution on faceplate or control panel. Allow surface to dry thoroughly before switching on the pump.

All functionality of the pump and cushion must be checked by a competent person after cleaning.

Cleaning the pump and pump bag:

- Do not immerse or soak the pump unit.
- Check for external damage before cleaning.
- Place the pump on a work surface and spray or wipe the outside of the case with a suitable cleaning solution.
- Wipe case with a clean cloth. Make sure all areas are clean.
- Spray cloth with cleaning solution and clean faceplate. Do not allow excess cleaning solution to pool on faceplate or control panel. Allow the surface to dry thoroughly after cleaning.
- Do not use a phenol-based cleaning solution as this may cause damage to the case.
- Plug pump into the mains and check for normal operation.
- The pump bag should be turned inside out and completely wiped down using disinfectant solution.
- Allow it to thoroughly air dry. Once the inside is dry, turn it back: wipe down the outside of the bag with disinfectant.

Please refer to cleaning instructions in the user manual accompanying the Accora chair for cleaning the chair covers.

If the air cushion is soiled and requires cleaning:

- Brush off or wipe down surfaces with liquid disinfectant.
- Repeat the process with the tubing set: spray, incubate, and then wipe clean.
- Allow all components to be dried completely.
- Drying of all the components must be done in a sunless area.

Disinfection:

- For extreme soiling control use a 5% Sodium Hypochlorite (bleach) solution.

11. STORAGE AND TRANSPORT

Warning:

- Do not store or use the cushion or pump in damp or wet areas.
- Do not position the cushion or pump near or against sources of direct heat or naked flames.
- The cushion must be protected when being transported to ensure the air cells are not damaged.
- The pump must not be dropped and must be transported in a protective box.

- Lay the cushion out flat and then roll it up. Do not fold, crease or stack the cushion.
- Unplug the pump and store with the proper identification tag.

12. PRODUCT DISPOSAL

- Disposal of this product should be in accordance with local regulations.











13. WARRANTY

The Elata® Air Cushion system is designed for an expected service life as listed below under normal use, conditions, and with appropriate periodic maintenance.

- Elata® Air Cushion
- Elata® Pump

The warranty period for the Elata® Air Cushion system is 12 months, covering parts and labor only. We require a purchase order for any parts dispatched, warranty or otherwise. Any issues regarding the warranty should be addressed in the first instance to your supplier. To report a problem, please contact Enable Lifecare.

14. TABLE OF SYMBOLS

SYMBOL	USE
	Refer to instructions for use
	Warning, beware of potential hazard – refer to instruction for use
	Model number
	Serial number
	Manufacturer
	Indoor use only
	Do not dispose of in domestic refuse
	Caution: risk of electrical shock
	Type BF applied part
	Class II double insulated

Enable Lifecare Pty Ltd



2 Selgar Avenue, Tonsley SA 5042
1300 370 370
support@enablelifecare.com.au

www.enablelifecare.com.au